

1103



FEATURES

- For internet / intranet access and branch office connectivity
- One 10/100Mbps Fast Ethernet port
- Upto 2 WAN ports, choice of
 - 2 V.35
 - 1 V.35 and 1 ISDN-S
 - 1 E1 and 1 V.35
- One Console port
- Compact size table top unit

Cost-effective solution for branch office connectivity

The CYGNUS 1103 Access Router is ideal for Internet access, point-to-point networking between two offices and intranet connection.

Its powerful Power PC based design and compliance with standard RFCs allows the CYGNUS 1103 to be used as an access device in large multi-location networks.

The WAN interface on the product is upto 2 ports, with a choice of 2 V.35 ports, 1 V.35 and 1 ISDN-S or 1 E1 and 1 V.35 are ordering time options.

Control and management of the unit is via menu driven supervisory software which can be accessed either through console port or through TELNET over the network. SNMP support is also provided.

The CYGNUS 1103 comes to you from Cygnus, which has been offering reliable, cost-effective datacom and networking products in India for several years. Since Cygnus designs and manufactures its products in-house it is in a position to offer comprehensive technical support for its products.

TYPICAL APPLICATION

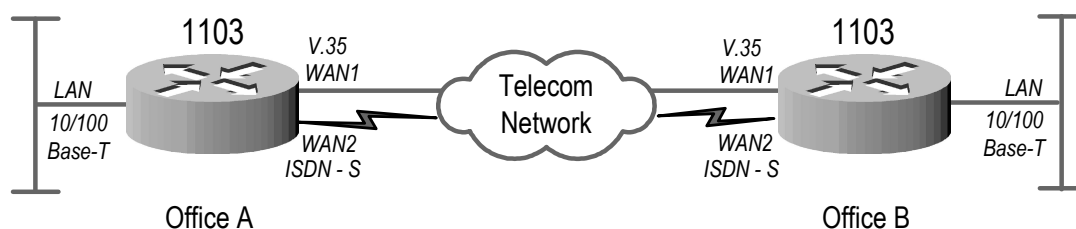

Hardware

- **CPU**
Freescale Power PC 32-bit CPU
- **Memory**
Flash Memory: 8M Bytes (Max 16MB)
SDRAM: 32M Bytes (Max 64MB)
- **WAN Port**
2 V.35 (DB 25)
1 V.35 (DB-25) and 1 ISDN-S (RJ-45)
1E1 (RJ-45) and 1 V.35 (DB-25)
Speed support upto 2 Mbps
(Any one ordering time option)
- **LAN Port**
1 10/100M Fast Ethernet port (RJ-45)
- **Console Port**
1 Asynchronous RS232 (DB 9)

- **Reliability**
Port Backup
- **Routing**
Static
RIP
OSPF
- **Security**
AAA Radius
Firewall
- **Management**
SNMP V1/2
Console
Telnet
FTP

Software

- **Data Link Layer**
PPP
HDLC
SLIP
Ethernet
- **Network Layer**
ARP
Proxy ARP
DNS
NAT
ICMP
IGMP
DHCP (Server/Client)

General

- **Power**
195-264 VAC 5W max
(External adaptor supplied)
- **Operating Temperature**
0-50 deg C, 5-95% RH (non condensing)
- **Dimensions (L x W x H)**
260mm x 157mm x 42mm

TYPICAL APPLICATIONS

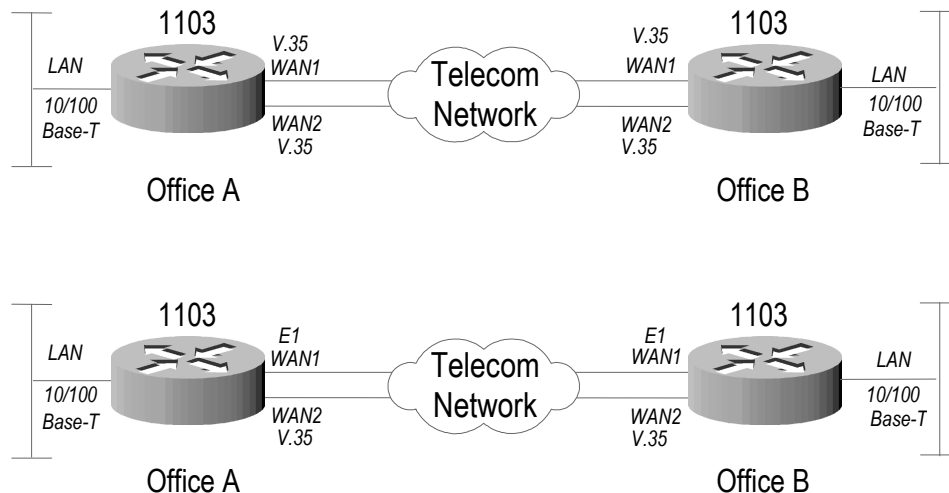

Note: Specifications are subject to change without notice
Ref.:071108



CYGNUS MICROSYSTEMS (P) LIMITED

93, IDA Phase II, Cherlapally, Hyderabad 500 051

Tel: +91 (40) 2726 1326 Fax: +91 (40) 2726 1167

URL: www.cygnusmicro.com e-mail: mktg@cygnusmicro.com

ISO 9001:2000
Registered Firm